

Ultra-Fine Needle Valves

Fine and Ultra-fine gas flow control valves for vacuum and pressure applications

Features

- o Ultra-low flow ranges from 0-20 cm³ min⁻¹ to 0-3 litre min⁻¹ air FS @ 1bar
- o Stainless Steel construction with Perlast seals
- o Helium Mass Spec. Leak Test to 10⁻⁸ mblsec⁻¹
- o Smooth opening, 6 turns to 2sccm, No.1
- o 1/16", 1/8", 1/4", 6mm or KF10 fittings
- o Optional Turns Counting Dial
- o Non-rising stem



The Ultra-fine range of stainless steel needle valves, offered by FTI, provide the finest gas flow control over typical ranges of 0-20, 0-1000 & 0-3000 std.cm³min⁻¹ air at 1bar differential pressure.

Designed for use in pressure or vacuum applications, they are ideal for use in gas analysers, chromatographs and mass spectrometers – in addition to any application where fine gas flow control is required.

The valve's opening characteristics are extremely smooth, preventing bursts of gas which would disturb delicate or Ultra-High Vacuum instrumentation.

Repeatability is also extremely good and the valves are available with a fully useable Turns Counting Dial, so that flow settings may be repeated time & time again.

Construction is in Stainless Steel, with Perlast® perfluoroelastomer body seals and a Fluorosint® orifice seal, for the best corrosion resistance.

Vacuum rated valves are leak tested on a helium mass spectrometer to <1x 10⁻⁸ mblsec⁻¹ and their shut-off achieves the same specification.

Valves are available with 1/16in single ferrule or 1/8in, 1/4in or 6mm twin ferrule compression fittings and additionally, vacuum models may be selected with NW10KF fittings.

The valve was developed specifically for mass spectrometry inlet service, probably the most critical application for such a valve but is eminently suitable for many other demanding applications where long-term stability is required.

Flow Ranges

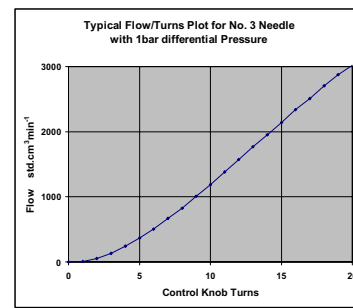
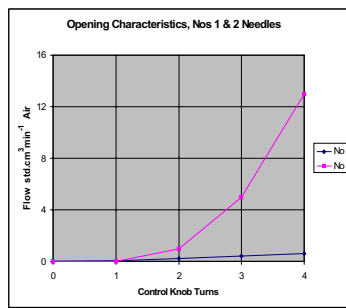
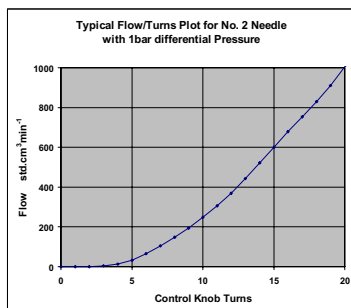
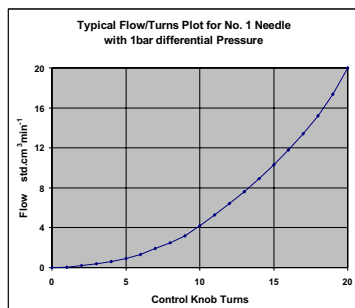

TOTALLY SMOOTH OPENING CHARACTERISTICS

The valves have been designed to provide totally smooth opening characteristics so that the user may guarantee that no gas will burst onto his process. This is an area that is overlooked by many competing needle valve designs. This is why our valves are ideal for accurate inlet control situations such as Ultra-High Vacuum applications.

Ultra-Fine Needle Valves

Helium Mass Spectrometer Leak Testing for Vacuum Valves



UHV Leak Testing

Seal design has been optimised to provide excellent sealing for both pressure and Ultra-High Vacuum applications.

All vacuum specification valves conform to a helium Mass spectrometer test to 1×10^{-8} mblsec⁻¹, which far exceeds the leak tightness of ordinary, commercial, needle valves.

The photograph (left) shows 16 valves being leak tested, mounted on a custom UHV manifold. They are tested with vacuum applied to the outlet port, as they would be used in service. The inlet port is blanked and the valve is then closed and opened so that both the external seals and the valve shut-off may be tested.

Dimensions

6MM FITTING

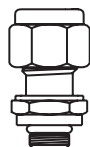

A = 34.0MM
B = 24.6MM

KF10 FLANGE

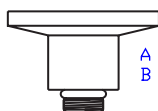

A = 26.0MM
B = 16.6MM

1/16" FITTING



A = 26.7MM
B = 17.3MM

1/8" FITTING



A = 29.6MM
B = 20.2MM

1/4" FITTING

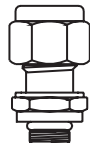

A = 34.0MM
B = 24.6MM

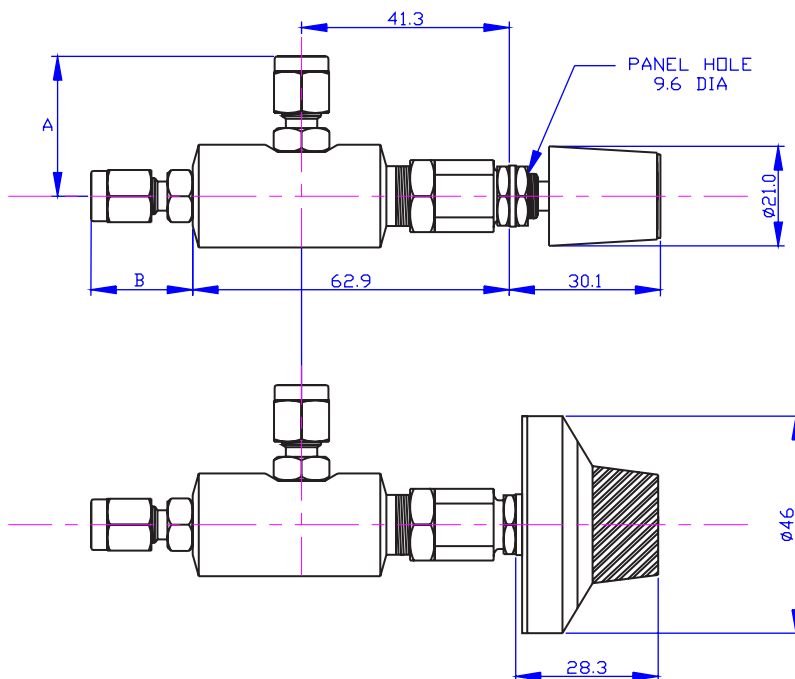

Specifications

Parameter	CMV
Flow Ranges, Air @ 1bar diff. pressure	Typically 20, 1000 and 3000 std.cm ³ min ⁻¹
Pressure Range	Vacuum to 18bar
Vacuum (VFM) Valve Leak Test	Valve open & closed: 1×10^{-9} mblsec ⁻¹
Wetted materials	316SS, 303SS, Fluorosint and Perlast
Dimensions	See Drawing
Weight	175g
Operating temperature range	+5 to +50°C
Storage temperature range	-20 to +70°C

Ordering Code

UV-P-11-VH

UV - ultra fine valve
FV - fine valve
MV - medium valve

VH - Vernier handle

P - pressure
V - vacuum

11 - 1/16" single ferrule
22 - 1/8" twin ferrule
44 - 1/4" twin ferrule
6M6M - 6mm twin ferrule
KF10KF10 - KF10 ended