

101 HM
MALE TEE

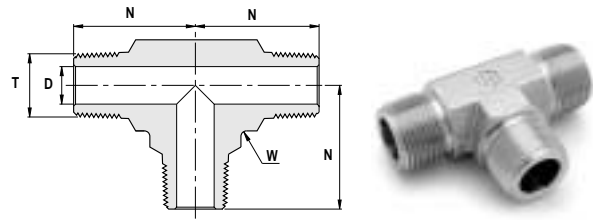

Ordering Information	T Male NPT Size	N		D Min. Opening		W Wrench Flat
		in	mm	in	mm	in
101HM _ 1/8	1/8	0.88	22.4	0.19	4.8	1/2
101HM _ 1/4	1/4	1.05	26.7	0.28	7.1	5/8
101HM _ 3/8	3/8	1.17	29.7	0.38	9.6	13/16
101HM _ 1/2	1/2	1.45	36.8	0.47	11.9	15/16

102 H
CROSS

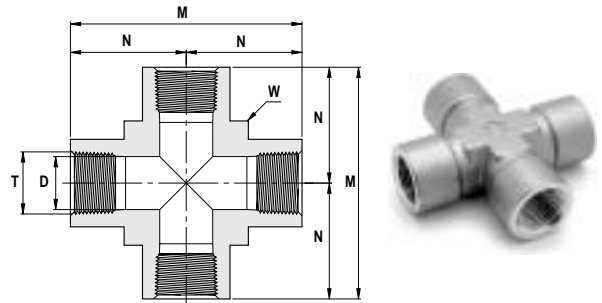

Ordering Information	T Female NPT Size	N		M		D Min. Opening		W Wrench Flat
		in	mm	in	mm	in	mm	in
102H _ 1/8	1/8	1.04	26.4	2.08	52.8	0.34	8.6	5/8
102H _ 1/4	1/4	1.17	29.7	2.34	59.4	0.45	11.4	13/16
102H _ 3/8	3/8	1.42	36.1	2.84	72.2	0.59	15.0	15/16
102H _ 1/2	1/2	1.56	39.6	3.12	79.2	0.73	18.5	1 1/8
102H _ 3/4	3/4	1.92	48.8	3.84	97.6	0.94	23.9	1 3/8
102H _ 1	1	1.91	48.5	3.82	97.0	1.17	29.7	1 11/16

103 H
HEX COUPLING

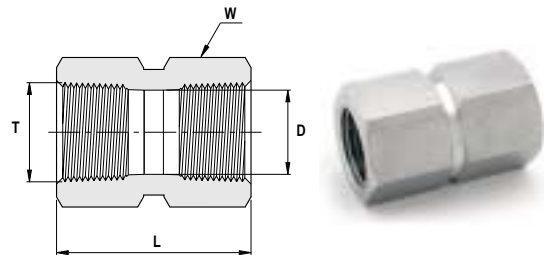

Ordering Information	T Female NPT Size	L		D Min. Opening		W Hex. Flat
		in	mm	in	mm	in
103H _ 1/8	1/8	0.81	20.6	0.34	8.6	9/16
103H _ 1/4	1/4	1.19	30.2	0.45	11.4	3/4
103H _ 3/8	3/8	1.31	33.3	0.59	15.0	7/8
103H _ 1/2	1/2	1.56	39.6	0.73	18.5	1 1/16
103H _ 3/4	3/4	1.62	41.1	0.94	23.9	1 5/16
103H _ 1	1	2.00	50.8	1.17	29.7	1 5/8

● Dimensions are for reference only, and are subject to change without notice.