

765 L
UNION ELBOW

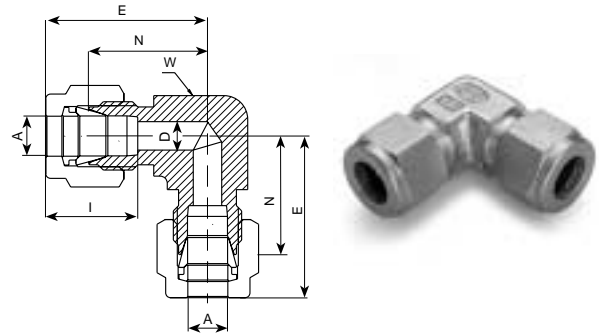

TUBE (METRIC) TO TUBE (METRIC)										
Ordering Information	A Tube O.D.		D		W Wrench Flat		N	E		I
	mm	mm	mm	mm	in	mm	mm	mm	mm	
765L_3	3		2.4		3/8	9.5	15.7		22.3	12.9
765L_4	4		2.4		1/2	12.7	18.8		25.4	13.7
765L_6	6		4.8		1/2	12.7	19.6		27.0	15.3
765L_8	8		6.4		9/16	14.3	21.3		28.8	16.2
765L_10	10		7.9		11/16	17.5	23.9		31.5	17.2
765L_12	12		9.5		13/16	20.6	25.9		36.0	22.8
765L_14	14		11.1		15/16	23.8	27.9		38.0	24.4
765L_15	15		11.9		15/16	23.8	27.9		38.0	24.4
765L_16	16		12.7		15/16	23.8	27.9		38.0	24.4
765L_18	18		15.1		1 1/8	28.6	29.7		39.8	24.4
765L_20	20		15.9		1 3/8	34.9	34.5		44.6	26.0
765L_22	22		18.3		1 3/8	34.9	34.5		44.6	26.0
765L_25	25		21.8		1 3/8	34.9	36.8		49.1	31.3

TUBE (INCH) TO TUBE (INCH)												
Ordering Information	A Tube O.D.		D		W Wrench Flat		N		E		I	
	in	mm	in	mm	in	mm	in	mm	in	mm	in	mm
765L_1/16	1/16	1.58	.05	1.25	3/8	9.5	.55	14.00	.70	17.81	.34	8.7
765L_1/8	1/8	3.17	.09	2.28	3/8	9.5	.62	15.74	.88	22.35	.50	12.7
765L_3/16	3/16	4.76	.12	3.04	1/2	12.7	.74	18.80	1.00	25.40	.54	13.7
765L_1/4	1/4	6.35	.19	4.82	1/2	12.7	.77	19.56	1.06	26.92	.60	15.2
765L_5/16	5/16	7.93	.25	6.35	9/16	14.3	.84	21.33	1.13	28.70	.64	16.3
765L_3/8	3/8	9.52	.28	7.11	5/8	15.9	.91	23.11	1.20	30.48	.66	16.8
765L_1/2	1/2	12.70	.41	10.41	13/16	20.6	1.02	25.90	1.42	36.06	.90	22.9
765L_5/8	5/8	15.87	.50	12.70	15/16	23.8	1.10	27.94	1.50	38.10	.96	24.4
765L_3/4	3/4	19.05	.62	15.74	1 1/8	28.6	1.17	29.71	1.57	39.89	.96	24.4
765L_7/8	7/8	22.22	.72	18.28	1 3/8	34.9	1.36	34.5	1.76	44.70	1.02	25.9
765L_1	1	25.40	.88	22.35	1 3/8	34.9	1.45	36.83	1.93	49.00	1.23	31.3
765L_1 1/4	*1 1/4	31.75	1.09	27.7	1 11/16	42.9	1.75	44.5	2.62	66.50	1.62	41.1
765L_1 1/2	*1 1/2	38.10	1.34	34.0	2	50.8	2.00	50.8	3.07	78.00	1.97	50.0

* Including low friction paste, See page 12 ● "D" - Dimension is minimum opening. ● Dimensions are for reference only, and are subject to change without notice.